



Dutch truck (Euro 6).

Conversion kit for Italeri DAF XF 105. 1/24

Warning!

This kit requires to use a donor chassis. As default chassis we suggest to use Italeri DAF XF 105.

Please follow this instruction while assembling, otherwise you could face problems with assembling the model.

Photo-etched parts have sharp edges, please be careful.

This model kit contains small parts and is not suitable for children.

For building this model some modelling skills are required.

Symbols:

● - glue parts;

⊘ - do not glue parts;

→└ - bend parts;

! - attention;

← - moving parts;

? - your choice;

Numbers of photo-etched parts

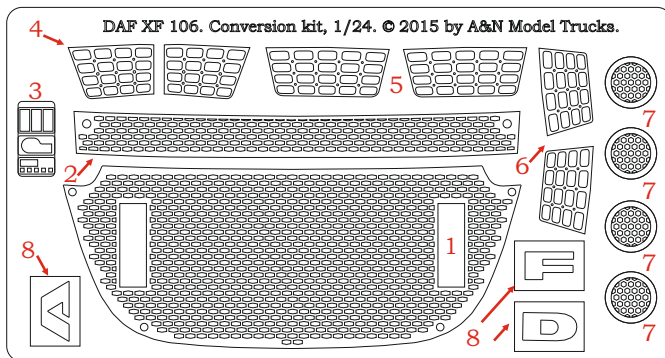

Dutch truck Euro 6. Conversion kit. 1/24

1.  x4

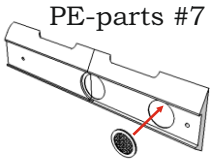

2.  x2

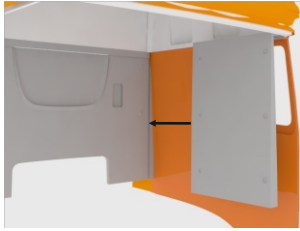

3.  x2



4. 
PE-part #3

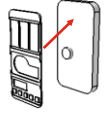

5. 



6. 

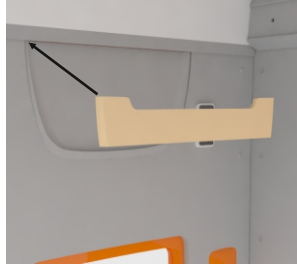

7. 



8. 



9. 



10. Cut

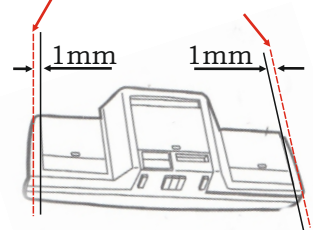

11. 

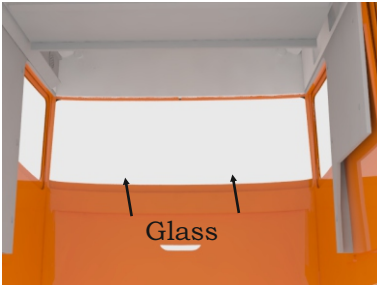

12. 



13.  x2

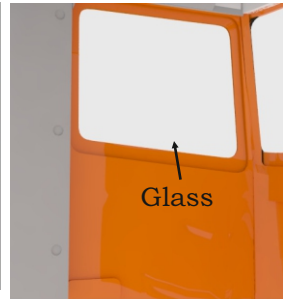

Dutch truck Euro 6. Conversion kit. 1/24

14.  x2

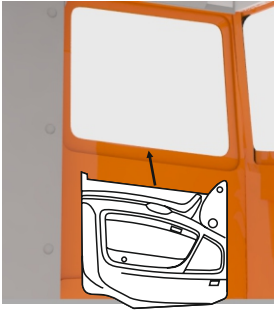

15. Cut

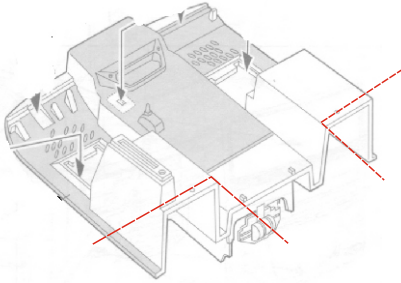

16. Cut

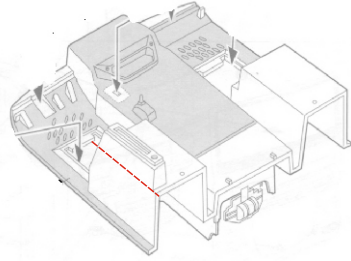

17.  x2



18.  x2

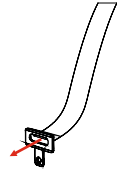

19.  x2

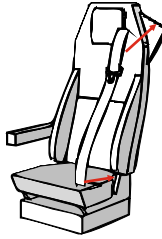

20.  x2

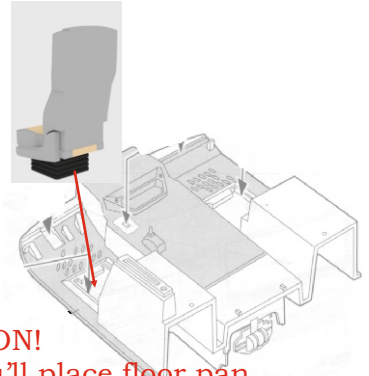

21. 

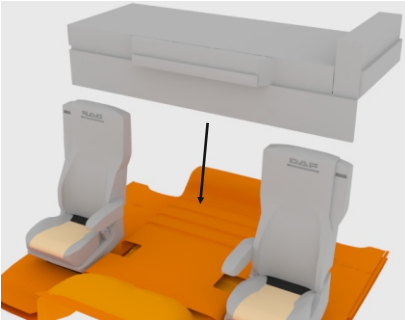

22.  ! **ATTENTION!**
When you'll place floor pan
in cab, there will be no way back!



23.  x2

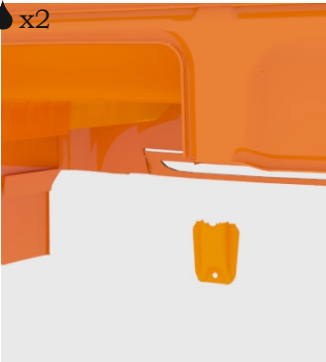

Dutch truck Euro 6. Conversion kit. 1/24

24. 

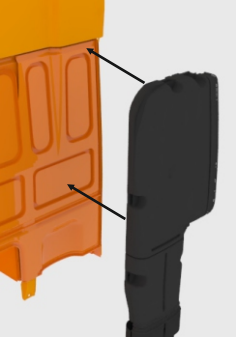

25.  x2

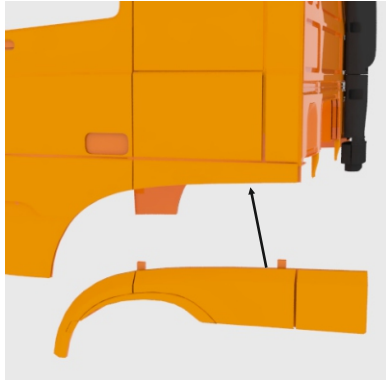

26.  x2 PE-parts #5

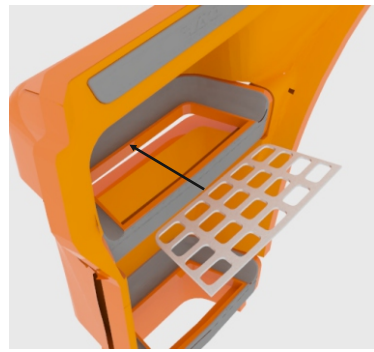

27.  x2 PE-parts #6



28.  x2

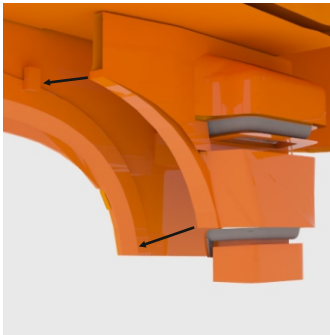

29.  x2

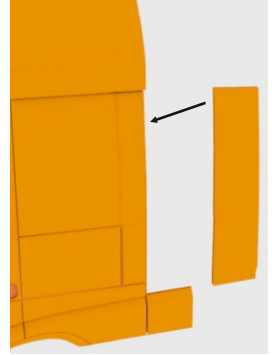

30.  x2

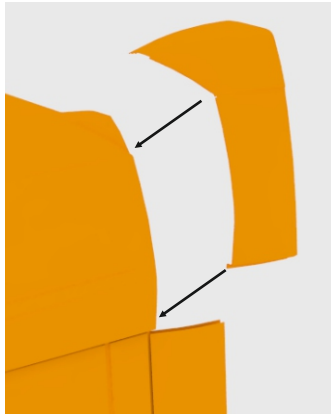

31.  x2



32.  PE-parts #8



33. 



Dutch truck Euro 6. Conversion kit. 1/24

34. 🟦

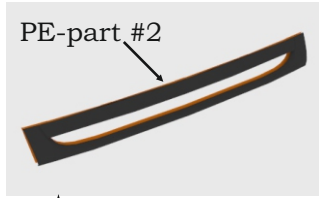

36. 🟦 x2

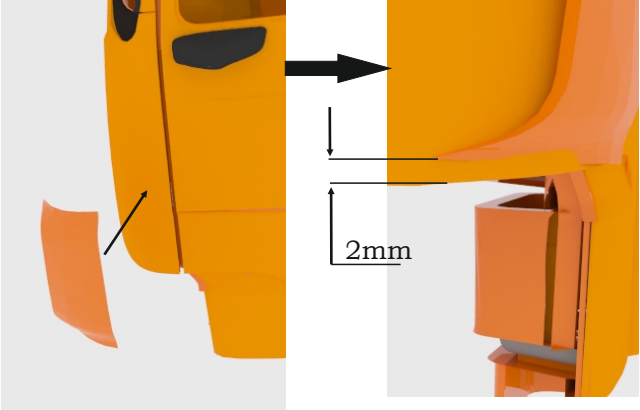

35. 🟦



37. 🟦



38. 🟦



39. 🟦 x2



40. 🟦



41. 🟦



42. 🟦 x2

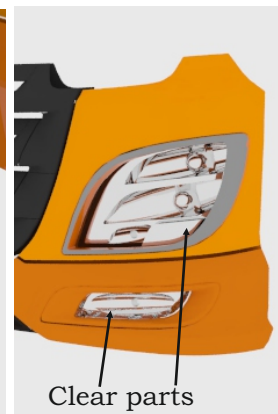

Dutch truck Euro 6. Conversion kit. 1/24

43. 

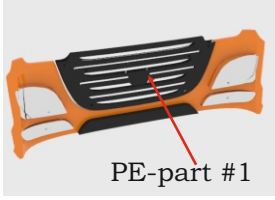

44.  x2

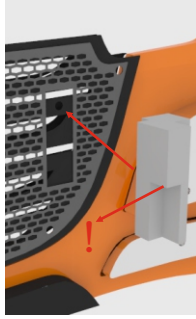

45. 



46.  x2

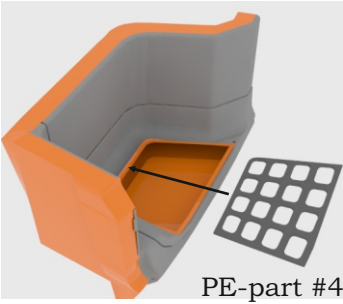

47.  x2



48.  x2

